

GBC Arctic Titan 165™ Roll Laminator

The GBC Arctic Titan is the coolest member of the Titan range. It is designed to protect and enhance a wide variety of inkjet prints that are sensitive to heat and cannot be finished using thermal activated films. The Arctic Titan™ is a cold only laminating machine and it can laminate and mount prints up to 1570mm wide using the range of GBC Arctic™ Pressure Sensitive Adhesive films.

- Scrap take-up reel conveniently winds release liner
- Roller gap adjusts up to 15mm for mounting
- Adjustable speed for operator comfort
- Infrared temperature control ensures fast heat recovery
- Foot pedal operation
- Stand rolls easily for maximum mobility
- Reverse motor clears feed jams

Features & Benefits

- 1 Digital Display / Control Panel:**
Simple LCD information centre indicates temperature, speed and ready/wait condition. The newly designed control panel allows the operator to easily make adjustments as needed to produce a quality finish.
- 2 Emergency Stop button:**
Safety operation
- 3 Foot pedal Operation:**
Hands free convenience
- 4 Designed for pressure sensitive film:**
Arctic range

Applications:

- Roll-ups
- Pop-ups
- Graphic mounting
- Posters
- Trade show graphics
- Signage

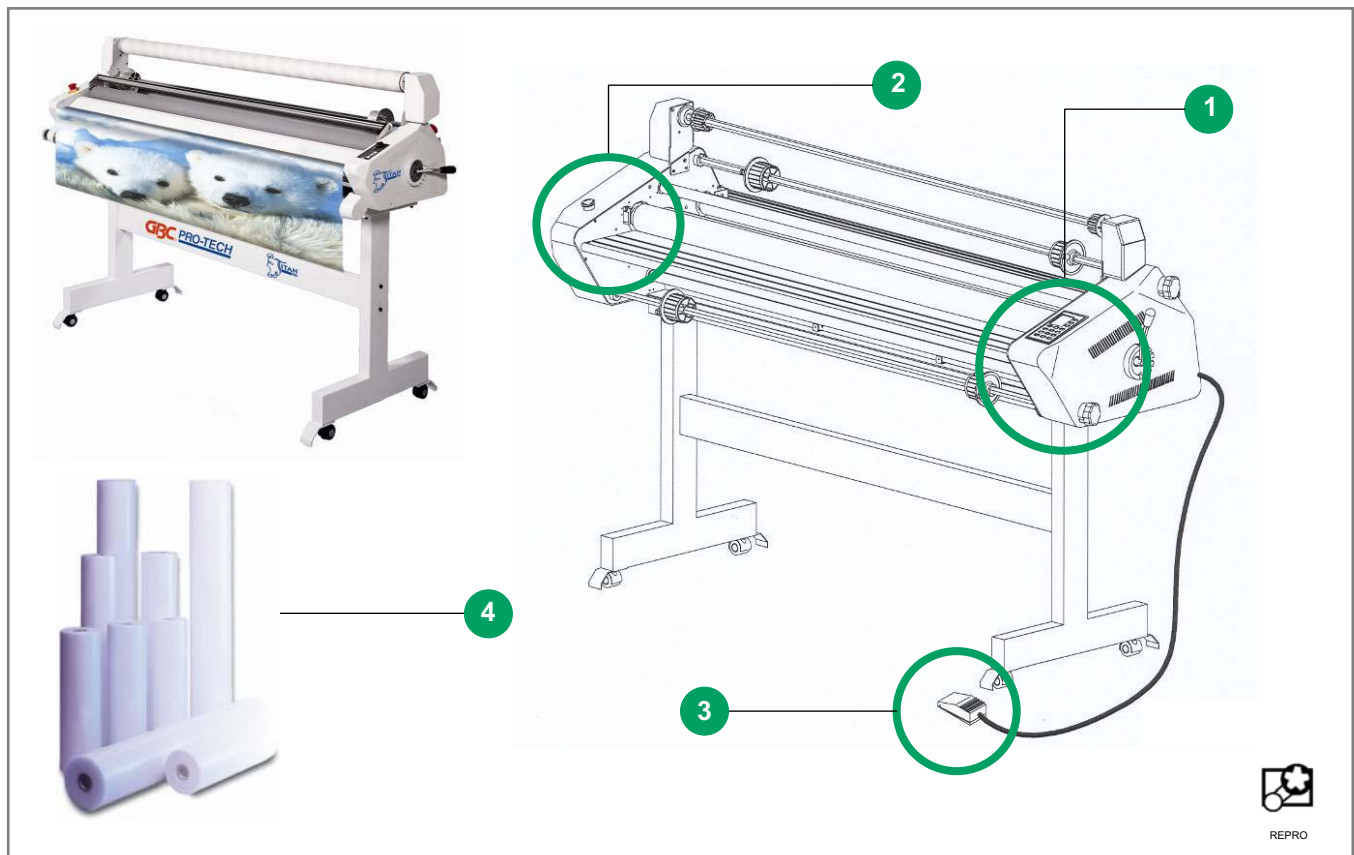

Technical Specifications

Maximum lamination width:	Pressure sensitive 1570mm
Maximum temperature:	N/A
Maximum speed:	1.8m/min
Maximum mounting thickness:	15 mm
Core size:	76mm incl. core adapter for 57mm
Unwinds:	2 unwind reels
Rewinds:	1 top liner rewind
Power requirements:	220V / 50Hz / 3 amp
Approximate weight:	128 kg
Machine dimensions:	1900 (w) x 1270 (h) x 635 (d) mm
Safety standards:	CE/ CSA /UL

Product Codes:

EU 1711940
UK 1711940